

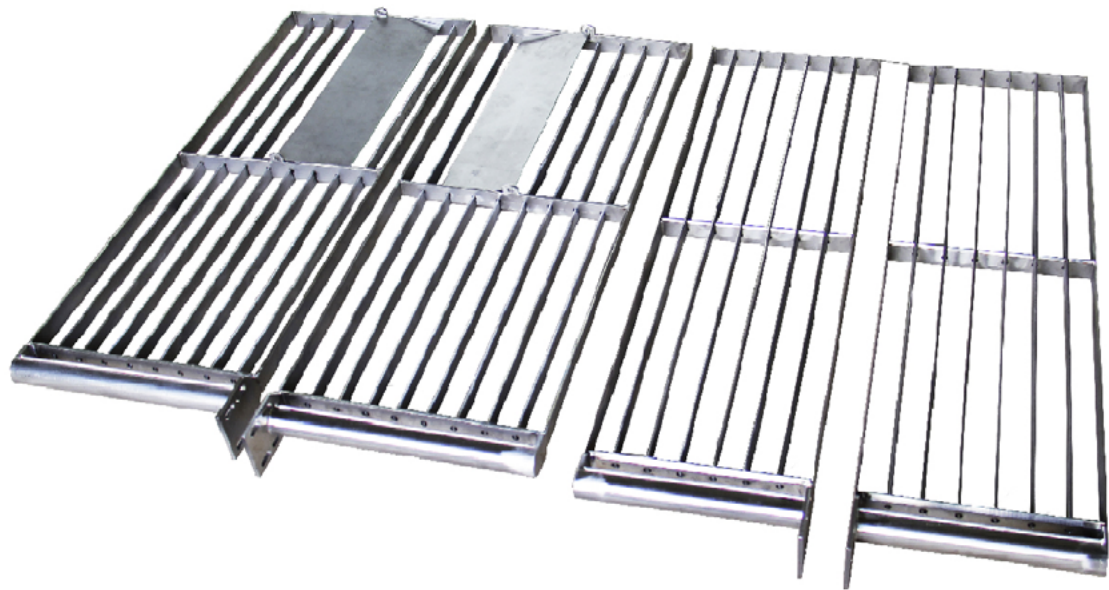

POLICON
Engineering & Manufacturing

***Cheese lyre for
mixing and cutting
cheese mass***



Description

Liras big and small are designed for mixing and cutting the cheese mass in a cheese bath.

Lyres are made of food-grade stainless steel.

Liras large and small consists of a welded frame with removable vertical knives. A bracket is welded to the upper contour of the frame for attaching the lyre to the drive of the cheese bath.

The big lyre additionally has a flat swivel shutter.

Big lyre

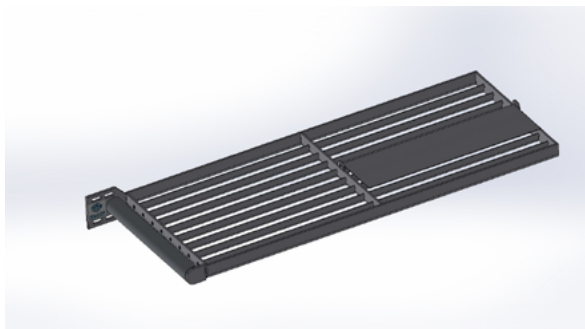

Small lyre

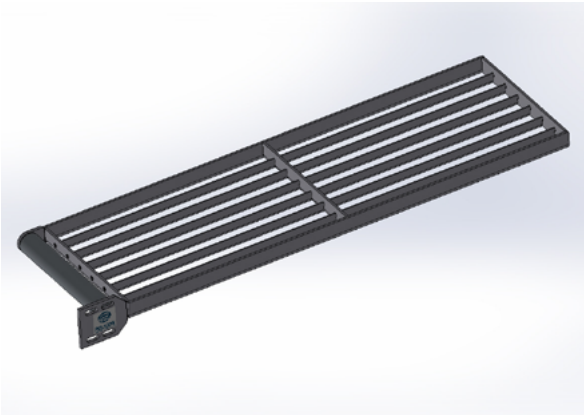

Technical Specification:

Overall dimensions of a big lyre, mm:

height	1 220
width	450
depth	100

The number of knives of big lyre 8

The mass of big lyre, kg 14,3

Overall dimensions of the small lyre, mm:

height	1 220
width	350
depth	100

The number of knives of small lyre..... 6

The mass of small lyre, kg..... 11

This product can be manufactured according to the customer’s technical specification, taking into account its specified parameters and features.

Full cycle engineering services

Food Machinery

Machinery for tires, rubber, plastics manufacturing

Machinery for the chemical and oil and gas industry

Machinery for the perfumery and cosmetic industry

Modernization and automation of production

Non-standart equipment

Production of spare parts, components, assemblies

Outsourcing services - repair and maintenance of equipment

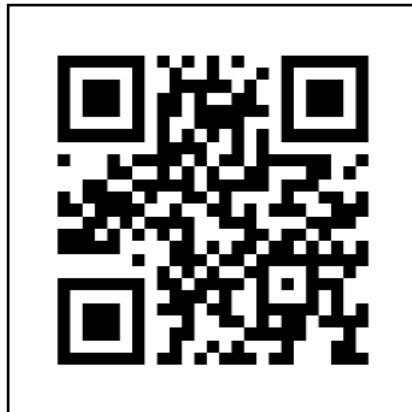

Policon JSCo

194 Lermontov Str, Omsk 644009, Russia

Tel./Fax: +7 (3812) 36 74 12, 36 74 02, 48 48 30

e-mail: info@policon-rt.ru

www.policon-rt.ru